

Fixing parts and accessories

Female hinge model

without bushes, with 4 screws, 1 bolt and retainer ring

Art. No. 156658 to 156668 (Type No. 453.001 to 453.011)

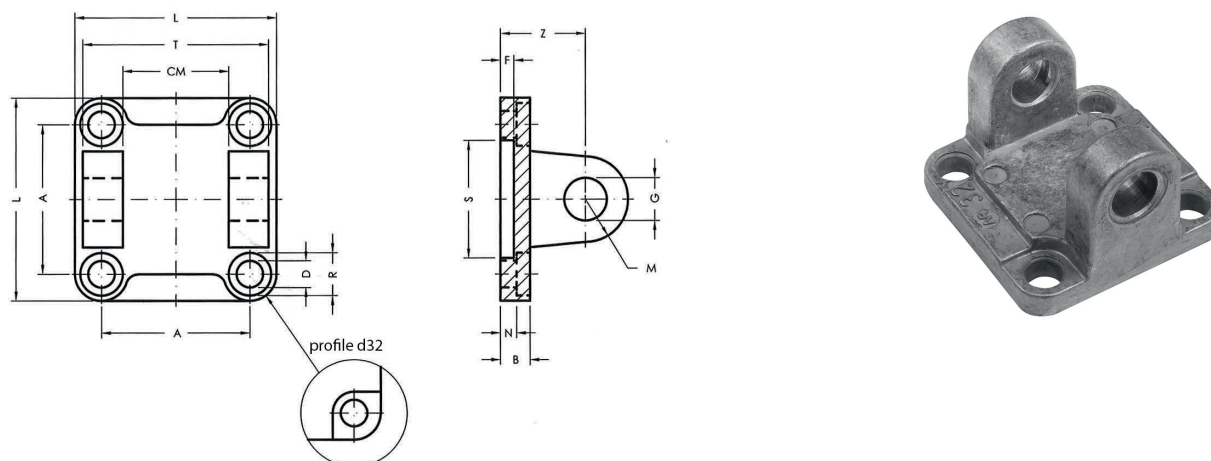

Dimensions

Art. No.	Type No.	Piston Ø mm	For cylinders	A	L	D	R	N	weight (g)
156658	453.001	32	acc. ISO 15552, ISO 21287	32.5	45.0	6.6	11.0	5.5	48
156659	453.002	40	acc. ISO 15552, ISO 21287	38.0	52.0	6.6	11.0	5.5	75
156660	453.003	50	acc. ISO 15552, ISO 21287	46.5	65.0	9.0	15.0	6.5	124
156661	453.004	63	acc. ISO 15552, ISO 21287	56.5	75.0	9.0	15.0	6.5	192
156662	453.005	80	acc. ISO 15552, ISO 21287	72.0	95.0	11.0	18.0	10.0	380
153663	453.006	100	acc. ISO 15552, ISO 21287	89.0	115.0	11.0	18.0	10.0	620
156664	453.007	125	acc. ISO 15552, ISO 21287	110.0	140.0	14.0	20.0	10.0	1180
156665	453.008	160	acc. ISO 15552	140.0	180.0	18.0	26.0	10.0	1780
156666	453.009	200	acc. ISO 15552	175.0	220.0	18.0	26.0	11.0	2900
156667	453.010	250	acc. ISO 15552	220.0	270.0	22.0	33.0	11.0	5800
156668	453.011	320	acc. ISO 15552	270.0	350.0	26.0	39.0	15.0	5800

Art. No.	Type No.	Piston Ø mm	B	S	F	Z	G	M	CM	T	Material
156658	453.001	32	9.0	30.0	5.0	22.0	10.0	10.0	26.0	45.0	Aluminium
156659	453.002	40	9.0	35.0	5.0	25.0	12.0	12.0	28.0	52.0	Aluminium
156660	453.003	50	11.0	40.0	5.0	27.0	12.0	12.0	32.0	60.0	Aluminium
156661	453.004	63	11.0	45.0	5.0	32.0	16.0	16.0	40.0	70.0	Aluminium
156662	453.005	80	14.0	45.0	5.0	36.0	16.0	16.0	50.0	90.0	Aluminium
153663	453.006	100	14.0	55.0	5.0	41.0	20.0	20.0	60.0	110.0	Aluminium
156664	453.007	125	20.0	60.0	7.0	50.0	25.0	25.0	70.0	130.0	Aluminium
156665	453.008	160	20.0	65.0	7.0	55.0	30.0	25.0	90.0	170.0	Aluminium
156666	453.009	200	25.0	75.0	7.0	60.0	30.0	25.0	90.0	170.0	Aluminium
156667	453.010	250	25.0	90.0	-	70.0	40.0	40.0	110.0	200.0	Aluminium
156668	453.011	320	30.0	110.0	-	80.0	45.0	45.0	120.0	220.0	Aluminium

(Values in mm)

Fixing parts and accessories

Female hinge model

with bushes, with 4 screws, 1 bolt and retainer ring

Art. No. 156669 to 156679 (Type No. 453.012 to 453.022)

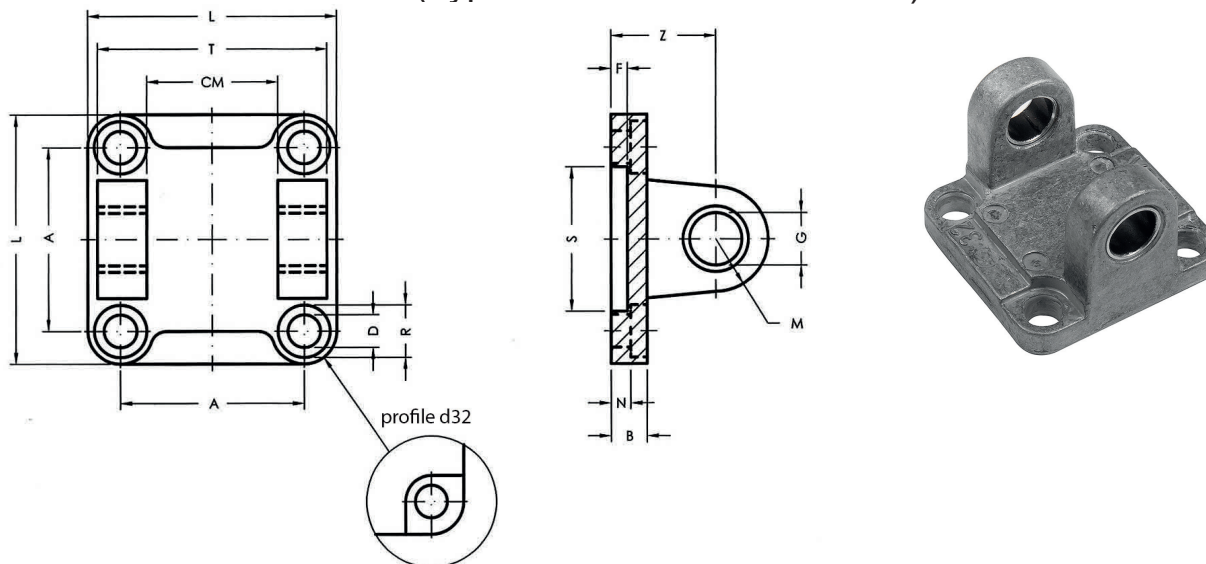

Dimensions

Art. No.	Type No.	Piston Ø mm	For cylinders	A	L	D	R	N	weight (g)
156669	453.012	32	acc. ISO 15552, ISO 21287	32.5	45.0	6.6	11.0	5.5	48
156670	453.013	40	acc. ISO 15552, ISO 21287	38.0	52.0	6.6	11.0	5.5	75
156671	453.014	50	acc. ISO 15552, ISO 21287	46.5	65.0	9.0	15.0	6.5	124
156672	453.015	63	acc. ISO 15552, ISO 21287	56.5	75.0	9.0	15.0	6.5	192
156673	453.016	80	acc. ISO 15552, ISO 21287	72.0	95.0	11.0	18.0	10.0	380
156674	453.017	100	acc. ISO 15552, ISO 21287	89.0	115.0	11.0	18.0	10.0	620
156675	453.018	125	acc. ISO 15552, ISO 21287	110.0	140.0	14.0	20.0	10.0	1180
156676	453.019	160	acc. ISO 15552	140.0	180.0	18.0	26.0	10.0	1780
156677	453.020	200	acc. ISO 15552	175.0	220.0	18.0	26.0	11.0	2900
156678	453.021	250	acc. ISO 15552	220.0	270.0	22.0	33.0	11.0	5800
156679	453.022	320	acc. ISO 15552	270.0	350.0	26.0	39.0	15.0	11000

Art. No.	Type No.	Piston Ø mm	B	S	F	Z	G	M	CM	T	Material
156669	453.012	32	9.0	30.0	5.0	22.0	10.0	10.0	26.0	45.0	Aluminium
156670	453.013	40	9.0	35.0	5.0	25.0	12.0	12.0	28.0	52.0	Aluminium
156671	453.014	50	11.0	40.0	5.0	27.0	12.0	12.0	32.0	60.0	Aluminium
156672	453.015	63	11.0	45.0	5.0	32.0	16.0	16.0	40.0	70.0	Aluminium
156673	453.016	80	14.0	45.0	5.0	36.0	16.0	16.0	50.0	90.0	Aluminium
156674	453.017	100	14.0	55.0	5.0	41.0	20.0	20.0	60.0	110.0	Aluminium
156675	453.018	125	20.0	60.0	7.0	50.0	25.0	25.0	70.0	130.0	Aluminium
156676	453.019	160	20.0	65.0	7.0	55.0	30.0	25.0	90.0	170.0	Aluminium
156677	453.020	200	25.0	75.0	7.0	60.0	30.0	25.0	90.0	170.0	Aluminium
156678	453.021	250	25.0	90.0	-	70.0	40.0	40.0	110.0	200.0	Aluminium
156679	453.022	320	30.0	110.0	-	80.0	45.0	45.0	120.0	220.0	Aluminium

(Values in mm)

Fixing parts and accessories

Female hinge model for articulated male hinge model

with 4 screws, 1 bolt and retainer ring

Art. No. 156680 to 156689 (Type No. 453.023 to 453.032)

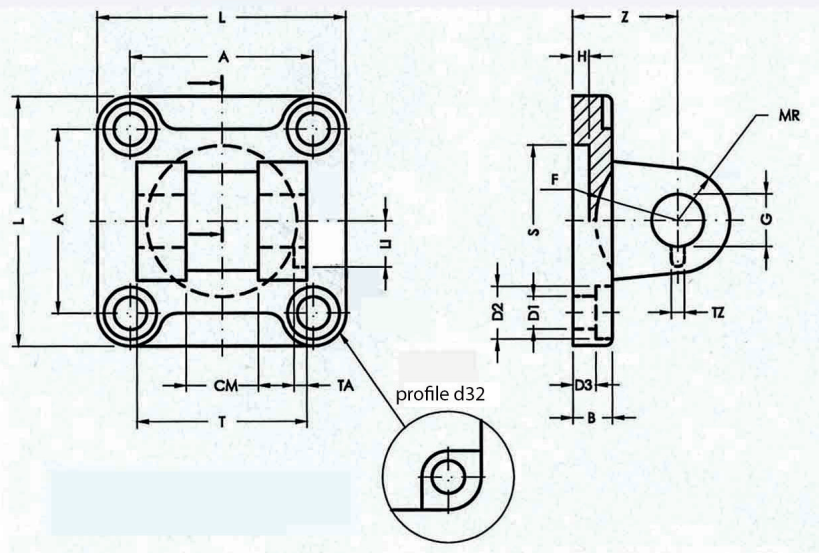

Dimensions

Art. No.	Type No.	Piston Ø mm	For cylinders	L	T	CM	A	Z	Material	weight (g)
156680	453.023	32	acc. ISO 15552, ISO 21287	45.0	34.0	14.0	32.5	22.0	Aluminium	42
156681	453.024	40	acc. ISO 15552, ISO 21287	52.0	40.0	16.0	38.0	25.0	Aluminium	70
156682	453.025	50	acc. ISO 15552, ISO 21287	65.0	45.0	21.0	46.5	27.0	Aluminium	112
156683	453.026	63	acc. ISO 15552, ISO 21287	75.0	51.0	21.0	56.5	32.0	Aluminium	194
156684	453.027	80	acc. ISO 15552, ISO 21287	95.0	65.0	25.0	72.0	36.0	Aluminium	382
156685	453.028	100	acc. ISO 15552, ISO 21287	115.0	75.0	25.0	89.0	41.0	Aluminium	610
156686	453.029	125	acc. ISO 15552, ISO 21287	140.0	97.0	37.0	110.0	50.0	Aluminium	1100
156687	453.030	160	acc. ISO 15552	180.0	122.0	43.0	140.0	55.0	Aluminium	2030
156688	453.031	200	acc. ISO 15552	220.0	122.0	43.0	175.0	60.0	Aluminium	3400
156689	453.032	250	acc. ISO 15552	270.0	125.0	49.0	220.0	70.0	Aluminium	5400

Art. No.	Type No.	Piston Ø mm	H	B	D3	S	G	MR	D1	D2	TA	TZ	LI	F
156680	453.023	32	5.0	9.0	5.5	30.0	10.0	10.0	6.6	11.0	3.0	3.3	11.5	17.0
156681	453.024	40	5.0	9.0	5.5	35.0	12.0	12.0	6.6	11.0	4.0	4.3	12.0	20.0
156682	453.025	50	5.0	11.0	6.5	40.0	16.0	14.0	9.0	15.0	4.0	4.3	14.0	22.0
156683	453.026	63	5.0	11.0	6.5	45.0	16.0	18.0	9.0	15.0	4.0	4.3	14.0	25.0
156684	453.027	80	5.0	14.0	10.0	45.0	20.0	20.0	11.0	18.0	4.0	4.3	16.0	30.0
156685	453.028	100	5.0	14.0	10.0	55.0	20.0	22.0	11.0	18.0	4.0	6.3	16.0	32.0
156686	453.029	125	7.0	20.0	10.0	60.0	30.0	25.0	14.0	20.0	6.0	6.3	24.0	42.0
156687	453.030	160	7.0	20.0	10.0	65.0	35.0	30.0	18.0	26.0	6.0	6.3	26.5	46.0
156688	453.031	200	7.0	25.0	11.0	75.0	35.0	30.0	18.0	26.0	6.0	6.3	26.5	49.0
156689	453.032	250	11.0	25.0	11.0	90.0	40.0	40.0	22.0	33.0	8.5	8.3	32.0	55.0

(Values in mm)

Fixing parts and accessories

Front female hinge model = discontinued product (no longer available)

with 4 screws, 1 bolt and retainer ring

Art. No. 156690 to 156700 (Type No. 453.033 to 453.043)

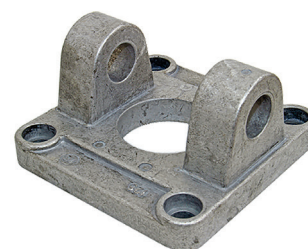
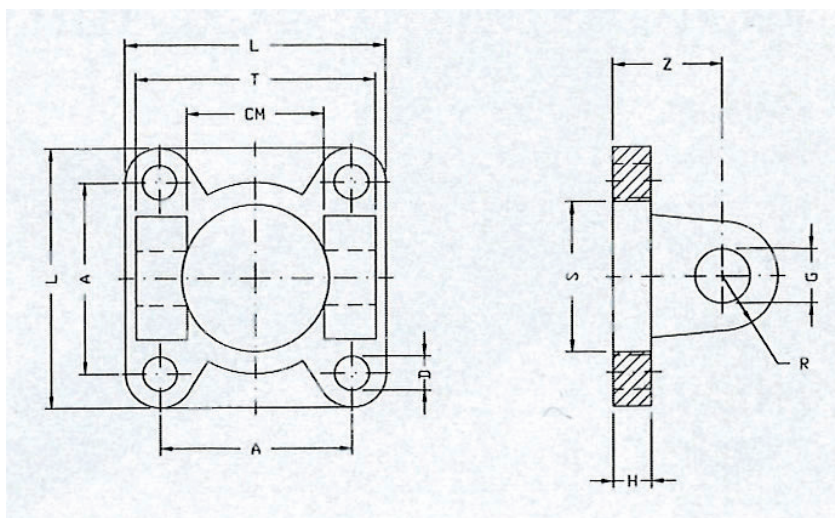

Dimensions

Art. No.	Type No.	Piston Ø mm	For cylinders			A	L	D	R	N	weight (g)
156690	453.033	32	acc. ISO 15552, ISO 21287			32.5	45.0	6.6	11	5.5	48
156691	453.034	40	acc. ISO 15552, ISO 21287			38.0	52.0	6.6	11	5.5	75
156692	453.035	50	acc. ISO 15552, ISO 21287			46.5	65.0	9.0	15	6.5	124
156693	453.036	63	acc. ISO 15552, ISO 21287			56.5	75.0	9.0	15	6.5	192
156694	453.037	80	acc. ISO 15552, ISO 21287			72.0	95.0	11.0	18	10.0	380
156695	453.038	100	acc. ISO 15552, ISO 21287			89.0	115.0	11.0	18	10.0	620
156696	453.039	125	acc. ISO 15552, ISO 21287			110.0	140.0	14.0	20	10.0	1180
156697	453.040	160	acc. ISO 15552			140.0	180.0	18.0	26	10.0	1780
156698	453.041	200	acc. ISO 15552			175.0	220.0	18.0	26	11.0	2900
156699	453.042	250	acc. ISO 15552			220.0	270.0	22.0	=	=	5800
156700	453.043	320	acc. ISO 15552			270.0	-	26.0	=	=	7500

Art. No.	Type No.	Piston Ø mm	B	S	F	Z	G	M	CM	T	Material
156690	453.033	32	9	30	5	22	10	10	26	45	Aluminium
156691	453.034	40	9	35	5	25	12	12	28	52	Aluminium
156692	453.035	50	11	40	5	27	12	12	32	60	Aluminium
156693	453.036	63	11	45	5	32	16	16	40	70	Aluminium
156694	453.037	80	14	45	5	36	16	16	50	90	Aluminium
156695	453.038	100	14	55	5	41	20	20	60	110	Aluminium
156696	453.039	125	20	60	7	50	25	25	70	130	Aluminium
156697	453.040	160	20	65	7	55	30	25	90	170	-
156698	453.041	200	25	75	7	60	30	25	90	170	-
156699	453.042	250	25	90	-	70	40	40	110	200	-
156700	453.043	320	30	110	-	80	45	45	120	220	-

(Values in mm)

Fixing parts and accessories

Male hinge model

without bush, with 4 screws

Art. No. 156777 to 156711 (Type No. 453.120 to 453.054)

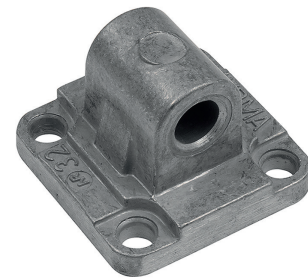
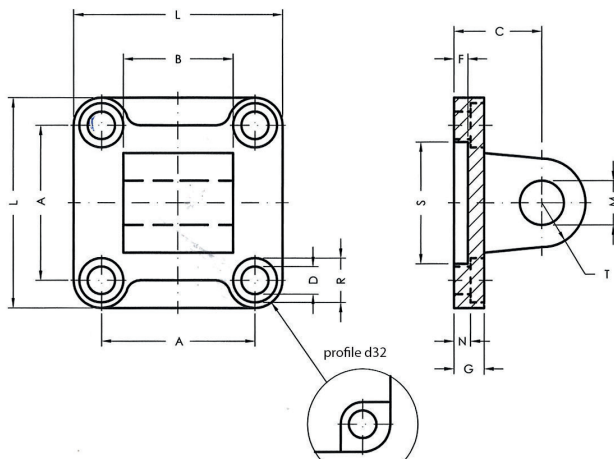

Aluminium

Dimensions

Art. No.	Type No.	Piston Ø mm	For cylinders	A	L	D	R	N	weight (g)
156777	453.120	16	acc. ISO 21287	18.0	27	4.5	-	-	17
		12+16	UNITOP						
156778	453.121	20	acc. ISO 21287, UNITOP	22.0	34	5.5	-	-	21
156779	453.122	25	acc. ISO 21287, UNITOP	26.0	38	5.5	-	-	27
156701	453.044	32	acc. ISO 15552, ISO 21287	32.5	45	6.6	11	5.5	54
156702	453.045	40	acc. ISO 15552, ISO 21287	38.0	52	6.6	11	5.5	76
156703	453.046	50	acc. ISO 15552, ISO 21287	46.5	65	9.0	15	6.5	124
156704	453.047	63	acc. ISO 15552, ISO 21287	56.5	75	9.0	15	6.5	212
156705	453.048	80	acc. ISO 15552, ISO 21287	72.0	95	11.0	18	10.0	420
156706	453.049	100	acc. ISO 15552, ISO 21287	89.0	115	11.0	18	10.0	666
156707	453.050	125	acc. ISO 15552, ISO 21287	110.0	140	14.0	20	10.0	1264
156708	453.051	160	acc. ISO 15552	140.0	180	18.0	26	10.0	1846
156709	453.052	200	acc. ISO 15552	175.0	220	18.0	26	11.0	2950
156710	453.053	250	acc. ISO 15552	220.0	270	22.0	33	11.0	6200
156711	453.054	320	acc. ISO 15552	270.0	350	26.0	39	15.0	11300

Art. No.	Type No.	Piston Ø mm	G	S	F	C	M	T	B	Material
156777	453.120	16	6	-	-	16	6	6	-	Aluminium
		12+16								
156778	453.121	20	6	-	-	20	8	8	-	Aluminium
156779	453.122	25	6	-	-	20	8	8	-	Aluminium
156701	453.044	32	9	30	5	22	10	10	26	Aluminium
156702	453.045	40	9	35	5	25	12	12	28	Aluminium
156703	453.046	50	11	40	5	27	12	12	32	Aluminium
156704	453.047	63	11	45	5	32	16	16	40	Aluminium
156705	453.048	80	14	45	5	36	16	16	50	Aluminium
156706	453.049	100	14	55	5	41	20	20	60	Aluminium
156707	453.050	125	20	60	7	50	25	25	70	Aluminium
156708	453.051	160	20	65	7	55	30	25	90	Aluminium
156709	453.052	200	25	75	7	60	30	25	90	Aluminium
156710	453.053	250	25	90	11	70	40	40	110	Aluminium
156711	453.054	320	30	110	11	80	45	45	120	Aluminium

(Values in mm)

Fixing parts and accessories

Male hinge model

with bush, with 4 screws

Art. No. 156780 to 156722 (Type No. 453.123 to 453.065)

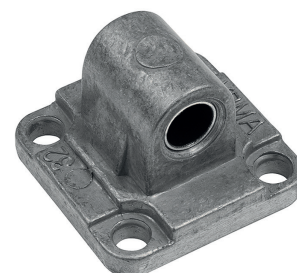
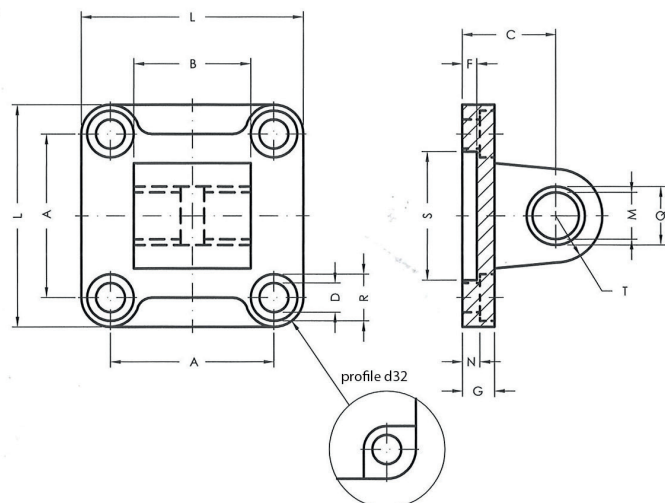

Dimension

Art. No.	Type No.	Piston Ø mm	For cylinders	A	L	D	R	N	weight (g)
156780	453.123	16	acc. ISO 21287	18.0	27	4.5	-	-	17
		12+16	UNITOP						
156781	453.124	20	acc. ISO 21287, UNITOP	22.0	34	5.5	-	-	21
156782	453.125	25	acc. ISO 21287, UNITOP	26.0	38	5.5	-	-	27
156712	453.055	32	acc. ISO 15552, ISO 21287	32.5	45	6.6	11	5.5	54
156713	453.056	40	acc. ISO 15552, ISO 21287	38.0	52	6.6	11	5.5	76
156714	453.057	50	acc. ISO 15552, ISO 21287	46.5	65	9.0	15	6.5	124
156715	453.058	63	acc. ISO 15552, ISO 21287	56.5	75	9.0	15	6.5	212
156716	453.059	80	acc. ISO 15552, ISO 21287	72.0	95	11.0	18	10.0	420
156717	453.060	100	acc. ISO 15552, ISO 21287	89.0	115	11.0	18	10.0	666
156718	453.061	125	acc. ISO 15552, ISO 21287	110.0	140	14.0	20	10.0	1264
156719	453.062	160	acc. ISO 15552	140.0	180	18.0	26	10.0	1846
156720	453.063	200	acc. ISO 15552	175.0	220	18.0	26	11.0	2950
156721	453.064	250	acc. ISO 15552	220.0	270	22.0	33	11.0	6200
156722	453.065	320	acc. ISO 15552	270.0	350	26.0	39	15.0	11000

Art. No.	Type No.	Piston Ø mm	G	S	F	C	Q	M	T	B	Material
156780	453.123	16	6	-	-	16	6	8	6	-	Aluminium
		12+16									
156781	453.124	20	6	-	-	20	8	10	8	-	Aluminium
156782	453.125	25	6	-	-	20	8	10	8	-	Aluminium
156712	453.055	32	9	30	5	22	12	10	10	26	Aluminium
156713	453.056	40	9	35	5	25	14	12	12	28	Aluminium
156714	453.057	50	11	40	5	27	14	12	12	32	Aluminium
156715	453.058	63	11	45	5	32	18	16	16	40	Aluminium
156716	453.059	80	14	45	5	36	18	16	16	50	Aluminium
156717	453.060	100	14	55	5	41	23	20	20	60	Aluminium
156718	453.061	125	20	60	7	50	28	25	25	70	Aluminium
156719	453.062	160	20	65	7	55	34	30	25	90	Aluminium
156720	453.063	200	25	75	7	60	34	30	25	90	Aluminium
156721	453.064	250	25	90	11	70	44	40	40	110	Aluminium
156722	453.065	320	30	110	11	80	50	45	45	120	Aluminium

(Values in mm)

Fixing parts and accessories

Counter-hinge model

CETOP RP107P

Art. No. 156723 to 156732 (Type No. 453.066 to 453.075)

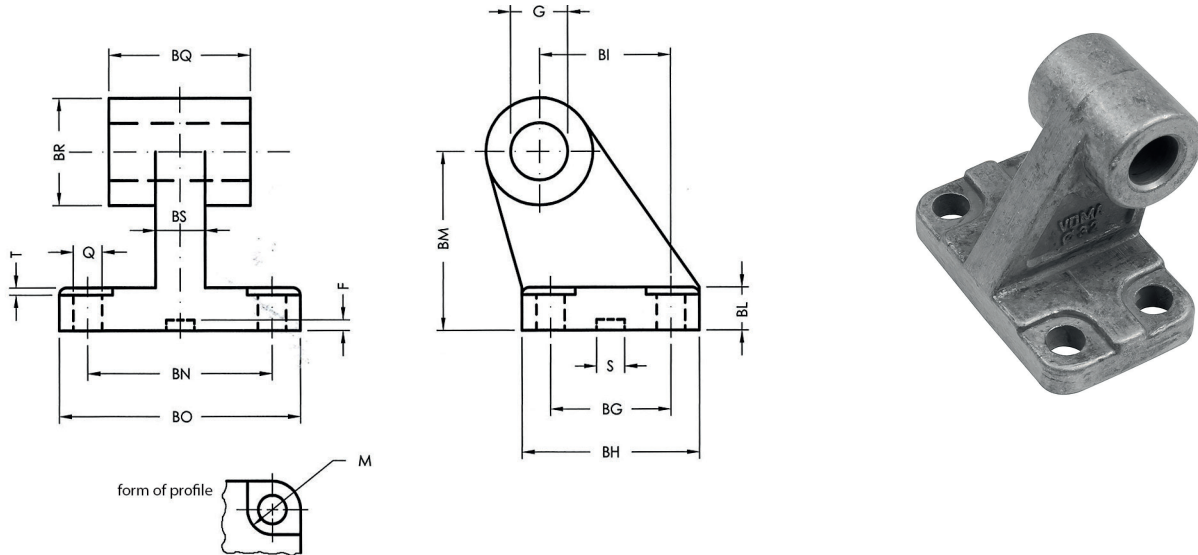

Dimension

Art. No.	Type No.	Piston Ø mm	For cylinders	Q	M	BG	BH	BI	weight (g)
156723	453.066	32	acc. ISO 15552, ISO 21287	6.6	11	18	31	21	56
156724	453.067	40	acc. ISO 15552, ISO 21287	6.6	11	22	35	24	139
156725	453.068	50	acc. ISO 15552, ISO 21287	9.0	15	30	45	33	142
156726	453.069	63	acc. ISO 15552, ISO 21287	9.0	15	35	50	37	200
156727	453.070	80	acc. ISO 15552, ISO 21287	11.0	18	40	60	47	312
156728	453.071	100	acc. ISO 15552, ISO 21287	11.0	18	50	70	55	656
156729	453.072	125	acc. ISO 15552, ISO 21287	14.0	20	60	90	70	826
156730	453.073	160	acc. ISO 15552	14.0	20	88	126	97	2600
156731	453.074	200	acc. ISO 15552	18.0	26	90	130	105	3250
156732	453.075	250	acc. ISO 15552	22.0	33	110	160	128	5700

Art. No.	Type No.	Piston Ø mm	BL	BM	BN	BO	BS	BR	T	G	S	F	BQ	Material
156723	453.066	32	8	32	38	51	10	20	1.6	10	10.5	3	26	Aluminium
156724	453.067	40	10	36	41	54	15	22	1.6	12	10.5	3	28	Aluminium
156725	453.068	50	12	45	50	65	16	26	1.6	12	10.5	3	32	Aluminium
156726	453.069	63	14	50	52	67	16	30	1.6	16	10.5	3	40	Aluminium
156727	453.070	80	14	63	66	86	20	30	2.5	16	10.5	3	50	Aluminium
156728	453.071	100	17	71	76	96	20	38	2.5	20	10.5	3	60	Aluminium
156729	453.072	125	20	90	94	124	30	45	3.2	25	10.5	3	70	Aluminium
156730	453.073	160	25	115	118	156	36	63	4.0	30	-	-	90	Aluminium
156731	453.074	200	30	135	122	162	40	63	4.0	30	-	-	90	Aluminium
156732	453.075	250	35	165	150	200	45	80	4.5	40	-	-	110	Aluminium

(Values in mm)

Fixing parts and accessories

Counter-hinge model

for fork model acc. DIN 71752

Art. No. 156733 to 156742 (Type No. 453.076 to 453.085)

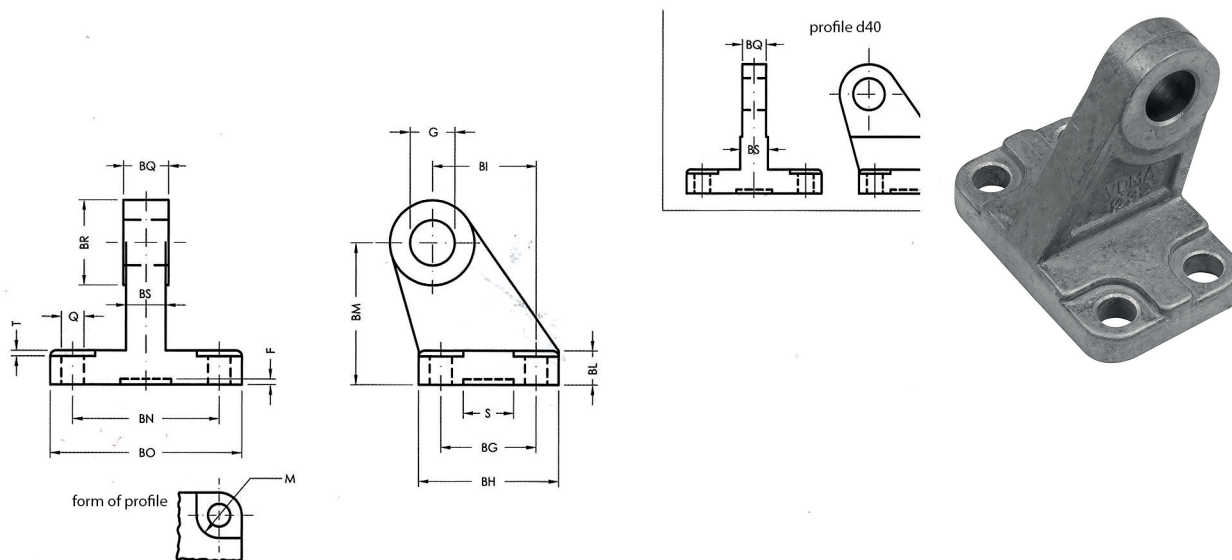

Dimension

Art. No.	Type No.	Piston Ø mm	For cylinders	Q	M	BG	BH	BI	weight (g)
156733	453.076	25	ISO 6432	6.6	11	18	31	21	43
		32	Round cylinder not ISO 6432						
		32-40	ISO 21287						
		32	ISO 15552						
156734	453.077	40	Round cylinder not ISO 6432	6.6	11	22	35	24	68
		50-63	ISO 21287						
		40	ISO 15552						
156735	453.078	50	Round cylinder not ISO 6432	9.0	15	30	45	33	115
		80	ISO 21287						
		50	ISO 15552						
156736	453.079	100	ISO 21287	9.0	15	35	50	37	169
		63	ISO 15552						
156737	453.080	125	ISO 21287	11.0	18	40	60	47	260
		80	ISO 15552						
156738	453.081	100	ISO 15552	11.0	18	50	70	55	426
156739	453.082	125	ISO 15552	14.0	20	60	90	70	800
156740	453.083	160	ISO 15552	14.0	20	88	126	97	2500
156741	453.084	200	ISO 15552	18.0	26	90	130	105	3100
156742	453.085	250	ISO 15552	22.0	33	110	160	128	5500

(Values in mm)

Fixing parts and accessories

Counter-hinge model

for fork model acc. DIN 71752

Art. No. 156733 to 156742 (Type No. 453.076 to 453.085)

Art. No.	Type No.	Piston Ø mm	BL	BM	BN	BO	BS	BR	T	G	S	F	BQ	Material
156733	453.076	32	8	32	38	51	9.4	20	1.6	10	10.5	3	10	Aluminium
156734	453.077	40	10	36	41	54	15.0	-	1.6	12	10.5	3	12	Aluminium
156735	453.078	50	12	45	50	65	15.4	26	1.6	16	10.5	3	16	Aluminium
156736	453.079	63	14	50	52	67	15.4	30	1.6	16	10.5	3	16	Aluminium
156737	453.080	80	14	63	66	86	19.4	30	2.5	20	10.5	3	20	Aluminium
156738	453.081	100	17	71	76	96	19.4	38	2.5	20	10.5	3	20	Aluminium
156739	453.082	125	20	90	94	124	30.0	45	3.2	25	10.5	3	25	Aluminium
156740	453.083	160	25	115	118	156	36.0	63	4.0	35	-	-	35	Aluminium
156741	453.084	200	30	135	122	162	40.0	63	4.0	35	-	-	35	Aluminium
156742	453.085	250	35	165	150	200	45.0	80	4.5	42	-	-	42	Aluminium

(Values in mm)

Fixing parts and accessories

Articulated male hinge model

with 4 screws

Art. No. 156743 to 156753 (Type No. 453.086 to 453.096)

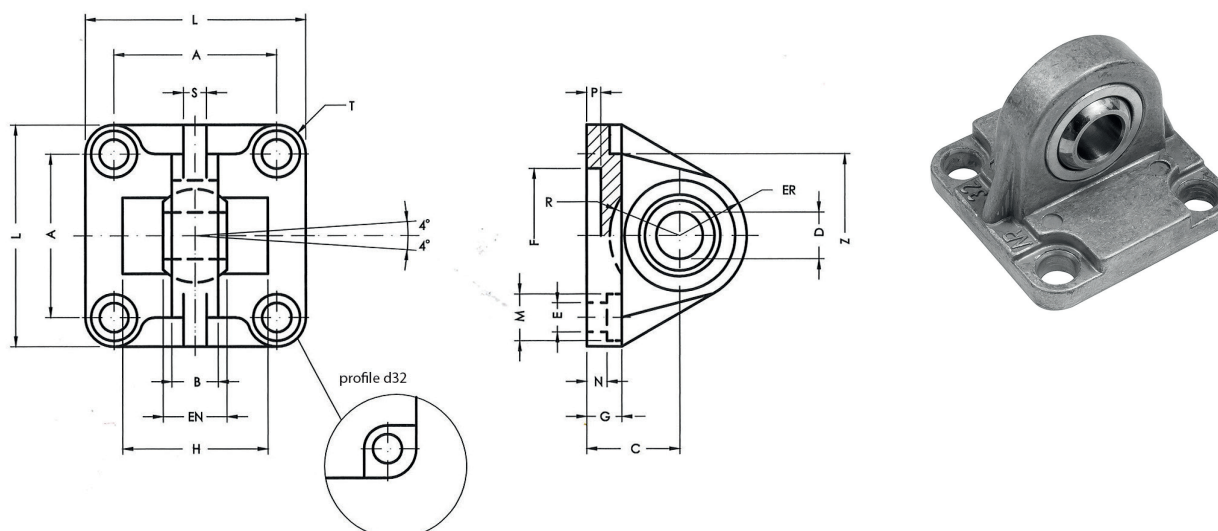

Dimensions

Art. No.	Type No.	Piston Ø mm	For cylinders								A	B	C	D	EN	weight (g)
156743	453.086	32	acc. ISO 15552, ISO 21287								32.5	10.5	22	10	14	62
156744	453.087	40	acc. ISO 15552, ISO 21287								38.0	12.0	25	12	16	100
156745	453.088	50	acc. ISO 15552, ISO 21287								46.5	15.0	27	16	21	180
156746	453.089	63	acc. ISO 15552, ISO 21287								56.5	15.0	32	16	21	244
156747	453.090	80	acc. ISO 15552, ISO 21287								72.0	18.0	36	20	25	476
156748	453.091	100	acc. ISO 15552, ISO 21287								89.0	18.0	41	20	25	646
156749	453.092	125	acc. ISO 15552, ISO 21287								110.0	25.0	50	30	37	1410
156750	453.093	160	acc. ISO 15552								140.0	28.0	55	35	43	2420
156751	453.094	200	acc. ISO 15552								175.0	28.0	60	35	43	3840
156752	453.095	250	acc. ISO 15552								220.0	33.0	70	40	49	5850
156753	453.096	320	acc. ISO 15552								270.0	45.0	80	50	60	7850
Art. No.	Type No.	Piston Ø mm	ER	F	G	E	L	M	N	P	H	R	S	Z	T	Material
156743	453.086	32	16.0	30	9	6.6	45	11	5.5	5	-	-	4	32.5	6.25	Aluminium
156744	453.087	40	19.0	35	9	6.6	52	11	5.5	5	-	-	6	39.0	7.0	Aluminium
156745	453.088	50	21.0	40	11	9.0	65	15	6.5	5	51	18	8	47.0	9.25	Aluminium
156746	453.089	63	24.0	45	11	9.0	75	15	6.5	5	-	-	8	52.0	9.25	Aluminium
156747	453.090	80	28.5	45	14	11.0	95	18	10.0	5	72	24	10	67.0	11.5	Aluminium
156748	453.091	100	30.0	55	14	11.0	115	18	10.0	5	-	-	10	77.0	13.0	Aluminium
156749	453.092	125	40.0	60	20	13.5	140	20	10.0	7	-	-	13	98.0	15.0	Aluminium
156750	453.093	160	45.0	65	20	18.0	180	26	10.0	7	-	-	14	130.0	20.0	Aluminium
156751	453.094	200	48.0	75	25	18.0	220	26	11.0	7	-	-	14	155.0	22.5	Aluminium
156752	453.095	250	52.0	90	25	22.0	270	33	11.0	11	-	-	19	205.0	25.0	Aluminium
156753	453.096	320	63.0	110	30	22.0	350	33	11.0	11	-	-	-	-	28.0	Aluminium

(Values in mm)

Fixing parts and accessories

Angle flange

1 piece with 4 screws

Art. No. 156754 to 156762 (Type No. 453.097 to 453.105)

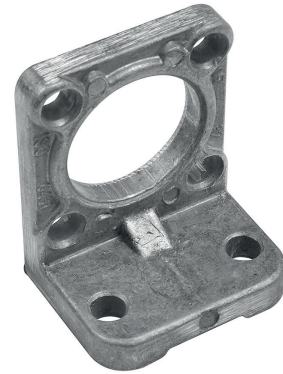
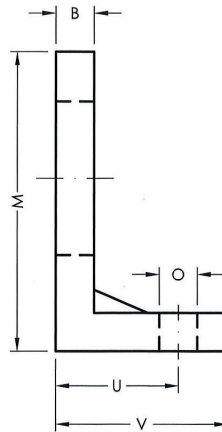
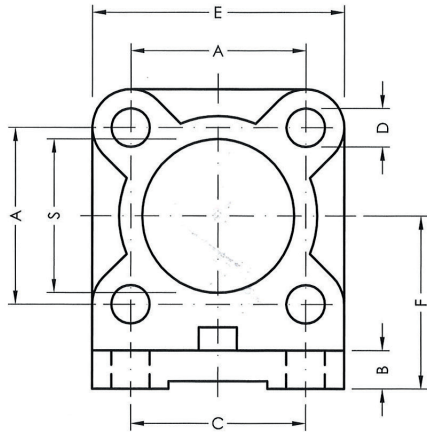

Dimensions

Art. No.	Type No.	Piston Ø mm	For cylinders			A	B	C	D	E	weight (g)
156754	453.097	32	acc. ISO 15552, ISO 21287			32.5	8	32	7	45	46
156755	453.098	40	acc. ISO 15552, ISO 21287			38.0	8	36	7	52	66
156756	453.099	50	acc. ISO 15552, ISO 21287			46.5	10	45	9	65	138
156757	453.100	63	acc. ISO 15552, ISO 21287			56.5	10	50	9	75	174
156758	453.101	80	acc. ISO 15552, ISO 21287			72.0	12	63	11	95	356
156759	453.102	100	acc. ISO 15552, ISO 21287			89.0	12	75	11	115	468
156760	453.103	125	acc. ISO 15552, ISO 21287			110.0	16	90	14	140	920
156761	453.104	160	acc. ISO 15552			140.0	20	115	18	180	2300
156762	453.105	200	acc. ISO 15552			175.0	20	135	18	220	3200

Art. No.	Type No.	Piston Ø mm	F	M	O	S	U	V	Material
156754	453.097	32	32	54.5	7	30	24	35	Aluminium
156755	453.098	40	36	62.0	9	35	28	35	Aluminium
156756	453.099	50	45	77.5	9	40	32	45	Aluminium
156757	453.100	63	50	87.5	9	45	32	45	Aluminium
156758	453.101	80	63	110.5	12	45	41	55	Aluminium
156759	453.102	100	71	128.0	14	55	41	56	Aluminium
156760	453.103	125	91	161.0	16	60	45	68	Aluminium
156761	453.104	160	115	205.0	18	65	60	82	Aluminium
156762	453.105	200	135	245.0	22	75	70	90	Aluminium

(Values in mm)

Fixing parts and accessories

Front or rear flange

with 4 screws

Art. No. 156783 to 156791 (Type No. 453.126 to 453.134)

156783

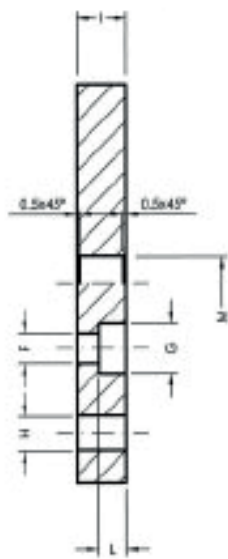
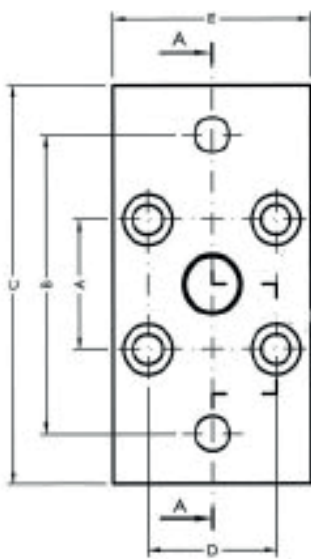

156786

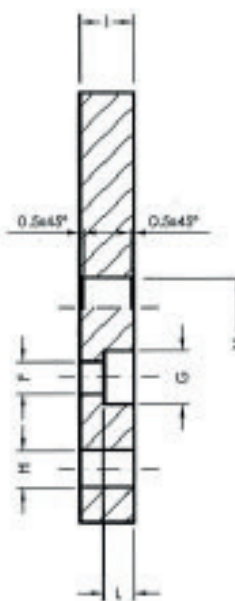
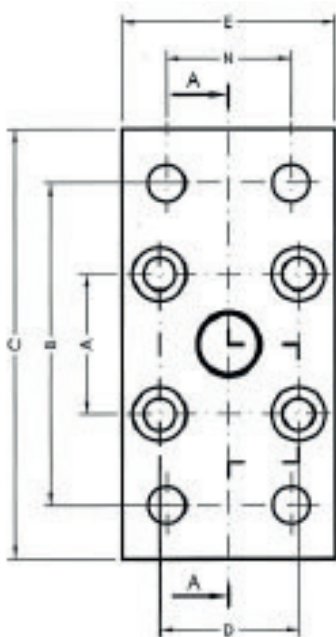

Fixing parts and accessories

Front or rear flange

with 4 screws

Art. No. 156783 to 156791 (Type No. 453.126 to 453.134)

Dimensions

Art. No.	Type No.	Piston-Ø mm	For cylinders	A	B	C	D	E	weight (g)
156783	453.126	16	acc. ISO 21287	18	43	55	18	29	34
		12+16	UNITOP						
156784	453.127	20	acc. ISO 21287, UNITOP	22	55	70	22	36	55
156785	453.128	25	acc. ISO 21287, UNITOP	26	60	76	26	40	68
156786	453.129	32	UNITOP	32	65	80	32	50	88
156787	453.130	40	UNITOP	42	82	102	42	60	143
156788	453.131	50	UNITOP	50	90	110	50	68	204
156789	453.132	63	UNITOP	62	110	130	62	87	411
156790	453.133	80	UNITOP	82	135	160	82	107	616
156791	453.134	100	UNITOP	103	163	190	103	128	890

Art. No.	Type No.	Piston-Ø	F	G	H	I	L	M	N	Material
156783	453.126	16	4.5	9	5.5	10	5.4	10	-	Aluminium
		12+16								
156784	453.127	20	5.5	10	6.6	10	5.4	12	-	Aluminium
156785	453.128	25	5.5	10	6.6	10	5.4	12	-	Aluminium
156786	453.129	32	6.6	11	7.0	10	6.4	14	32	Aluminium
156787	453.130	40	6.6	11	9.0	10	6.4	14	36	Aluminium
156788	453.131	50	9.0	15	9.0	12	8.6	18	45	Aluminium
156789	453.132	63	9.0	15	9.0	15	8.6	18	50	Aluminium
156790	453.133	80	11.0	18	12.0	15	10.6	23	63	Aluminium
156791	453.134	100	11.0	18	14.0	15	10.6	28	75	Aluminium

(Values in mm)